

PRESSURE REDUCING VALVE FOR STEAM RP 16

DESCRIPTION

The ADCA RP16 series pressure reducing valves are self-actuated direct action proportional action type, operating without auxiliary energy, designed for use on steam, compressed air and other gases. They are suitable for reducing steam pressure in all energy and process systems where pressures should be kept constant. Connections are flanged.

USE: Saturated steam, compressed air and other gases compatible with the construction.

AVAILABLE MODELS: RP16
SIZES: DN 15 to DN 50
CONNECTIONS: Flanged DIN
INSTALLATION: Horizontal installation.
 An "Y" strainer, steam separator and steam trap should be provided upstream the valve.
 See IMI, installation and maintenance instructions.

LIMITING CONDITIONS

Body design conditions : PN 16
 Maximum upstream pressure (steam) : 13 bar
 Maximum downstream pressure : 13 bar
 Minimum downstream pressure : 0,5 bar
 Maximum operating temperature : 200 °C
 Maximum reducing ratio : 5 : 1
 Maximum cold hydraulic test : 24 bar
 Max.hydraulic factory valve body test: 24 bar

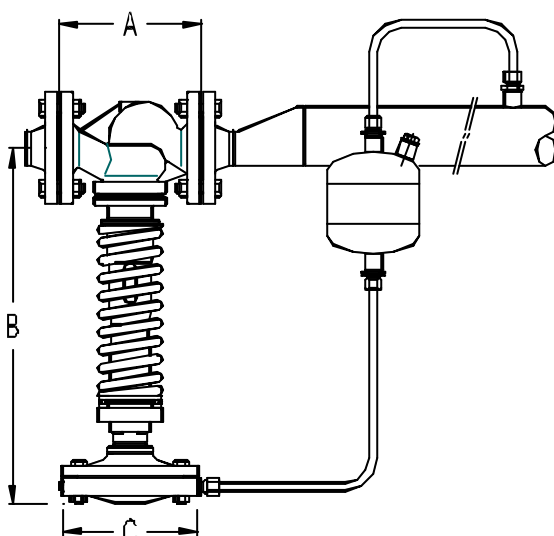
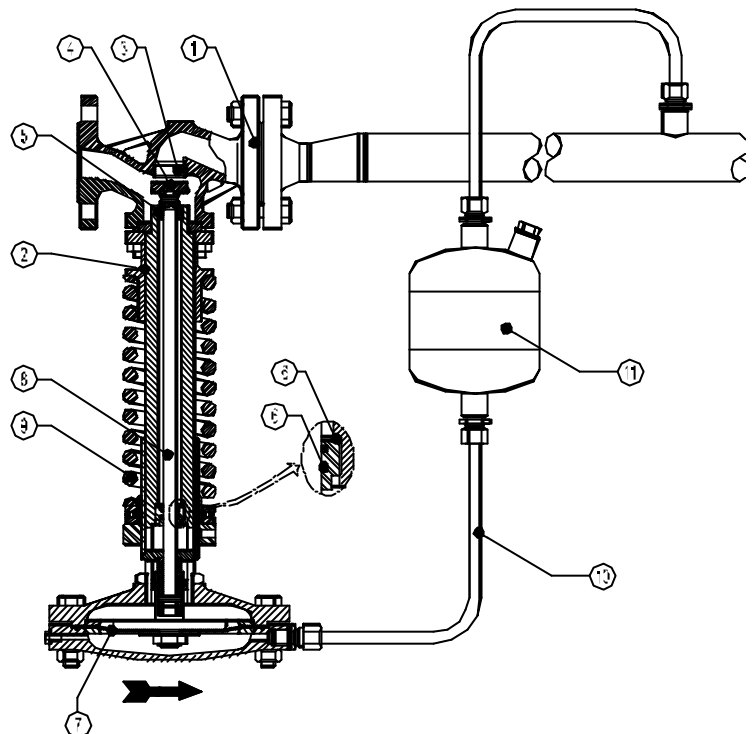

MATERIALS

POS.	DESIGNATION	MATERIAL
1	BODY (PN16)	GG 25
2	YOKE	C 40
3	VALVE SEAT	ST.STEEL
4	VALVE DISC	ST.STEEL
5	GUIDE	ST.STEEL
6 *	O-RINGS	NBR
7 *	DIAPHRAGM CHAMBER	GG25
8	SPINDLE	ST.STEEL
9	SPRING	SPRING STEEL
10 *	IMPULSE LINE	COPPER
11 *	CONDENSATE VESSEL	STEEL

* Available spare parts.

DIMENSIONS (mm)

DN	VALVE			ACTUATOR		
	A	B	Kg	TYPE	C	Kg
15	130	440	12,7	A1	172	4,3
20	150	440	12,7	A11	172	4,3
25	160	440	13,7	A2	220	7,3
32	180	445	15,7	A21	220	7,3
40	200	445	17,7	A3	282	11,3
50	230	540	25,7	A4	340	16,3

DN	15	20	25	32	40	50	
Kvs	2	3,5	5	9	12	22	

ACTUATOR AND SPRING SELECTION TABLE

VALVE	Kvs	ACTUATOR						
DN	m3/h		A -4	A -3	A -2	A -21	A -1	A -11
15	2	Outlet (bar) Spring Nr.	0,5 -0,99 60	1,0-1,6 60	1,7-3,8 60	3,9-5,5 60	5,6-8,2 60	8,3-13 60
20	3,5	Outlet (bar) Spring Nr.	0,5 -0,99 60	1,0-1,6 60	1,7-3,8 60	3,9-5,5 60	5,6-8,2 60	8,3-13 60
25	5	Outlet (bar) Spring Nr.	0,5 -0,99 60	1,0-1,6 60	1,7-3,8 60	3,9-5,5 60	5,6-8,2 60	8,3-13 60
32	9	Outlet (bar) Spring Nr.	0,5 -0,99 60	1,0-1,6 60	1,7-3,8 60	3,9-5,5 60	5,6-8,2 60	8,3-13 60
40	12	Outlet (bar) Spring Nr.	0,5 -0,99 60	1,0-1,6 60	1,7-3,8 60	3,9-5,5 60	5,6-8,2 60	8,3-13 60
50	22	Outlet (bar) Spring Nr.	0,5 -0,99 61	1,0-1,9 61	2,0-4,2 61	4,3-6,9 61	7,0-8,5 64	8,6-13 64

Valve selection : Please use the formulas mentioned on Valve Sizing IS.PV16G.55 E 01.05

How to order : RP16 DN 40 PN 16 valve complete with spring Nr.60 ,type A-21 actuator,condensate vessel and copper tube impulse line.

Remarks:

For superheated steam and pressures above 13 bar , please consult.

For determination of upstream and downstream pipe sizes please consult.

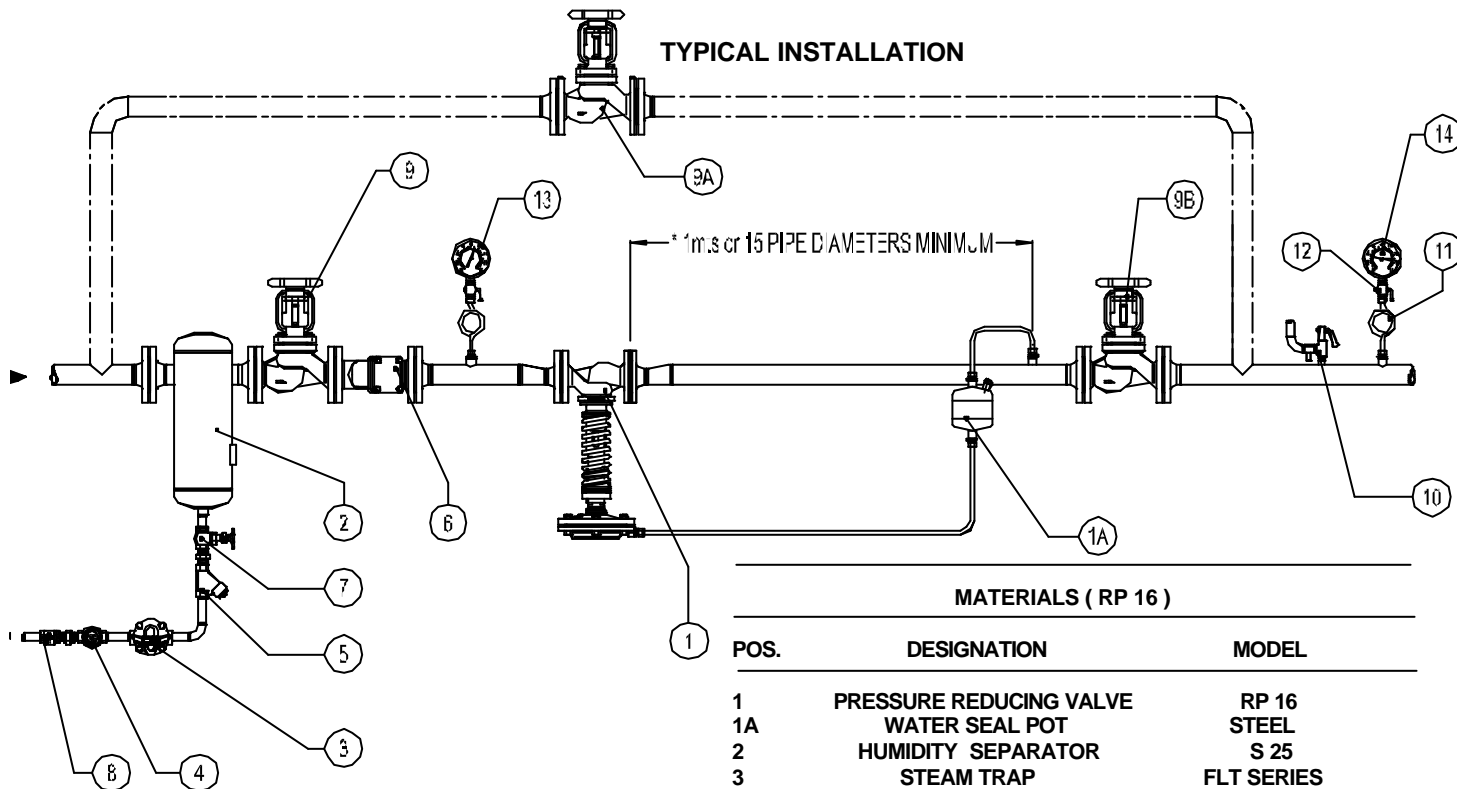

MATERIALS (RP 16)

POS.	DESIGNATION	MODEL
1	PRESSURE REDUCING VALVE	RP 16
1A	WATER SEAL POT	STEEL
2	HUMIDITY SEPARATOR	S 25
3	STEAM TRAP	FLT SERIES
4	SIGH GLASS	SW 12
5	STRAINER	IS 16
6	STRAINER	IS16F
7	STOP VALVE	GLOBE TYPE
8	CHECK VALVE	GLOBE TYPE
9	STOP VALVE	GLOBE OR GATE TYPE
9A*	BY-PASS VALVE	GLOBE TYPE
9B	STOP VALVE	GLOBE OR GATE TYPE
10	SAFETY VALVE	---
11	COIL	---
12	GAUGE COCK	---
13	UPSTREAM PRESSURE GAUGE	---
14	DOWNSTREAM PRESSURE GAUGE	---