

FLOAT AND THERMOSTATIC STEAM TRAPS FLT 50 & FLT 65 S (Fabricated Steel) (DN50 - DN100)

DESCRIPTION

FLT 50 S float and thermostatic (integral air vent) high capacity steam traps series are designed for all types of low and medium pressure steam heating and process equipment. Connections are flanged.

MAIN FEATURES

Modulating discharge.
Discharges condensate at steam temperature.
Unaffected by sudden or wide load and pressure changes.
Excellent air discharge (by thermostatic air vent).

OPTIONS: Equalizing plug , venting connection and drain plug (or blow-off valve on cover).
USE : Saturated steam.

AVAILABLE MODELS :

FLT 50 S & FLT 65 S-12 - steel construction
FLT 50 SS & FLT 65 SS-12 - stainless steel

SIZES :

FLT 50 - DN 50 and DN 65.
FLT 65 - DN 65, 80 and DN 100.

CONNECTIONS : Flanged DIN. Special flanges upon request.

INSTALLATION : Horizontal installation .
Vertical inlet - horizontal outlet.

How to order: i.e. FLT50 S DN 65 DIN

PMA :Max.allowable pressure 16 bar
TMA: Max.allowable temperature 300 °C
PMO: Max.operating pressure 12 bar
TMO: Max.operating temperature 250 °C
Max.differential pressure 12 bar

DIMENSIONS (mm)

		DIN FLANGES							
MODEL	SIZE	A	B	C	D	E	F	G	WEIGHT
FLT 50	50-65	430	350	263	475	145	273	290	70
FLT 65	65-100	480	440	270	570	176	355	360	110

All dimensions and weights are approximate.
Please consult factory for certified dimensions.

Alternative connections:

FLT 50 can be fitted with DN 50-65 connections
FLT 65 can be fitted with DN 65,80 and DN100 connections

FLOW RATE CAPACITY IN Kg/h

MODEL	SIZE	DIFFERENTIAL PRESSURE (bar)													
		0.5	1	1,5	2	2,5	3	3,5	4	5	6	7	8	10	12
FLT50- 12	50	11300	12500	13500	15000	16000	17500	18500	20000	20500	21500	22000	22500	23000	23500
FLT65- 12	65	20000	25000	27500	34000	37000	38000	39500	42000	43500	45500	47000	48000	49500	50000

Recommended safety factor : continuous 1.2 - 1.5 ; discontinuous flow 2 - 3 .

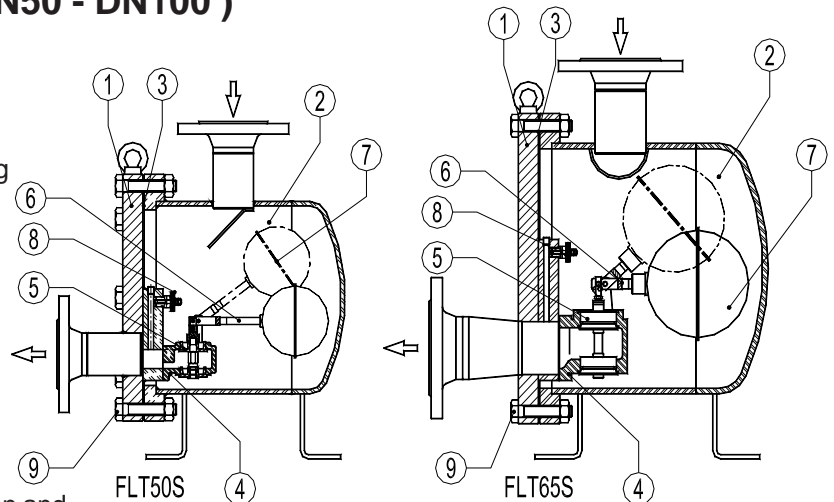
MATERIALS:

POS.NR.	DESIGNATION	MATERIAL
1	BODY	St 37-2 / C22.8 / H 11
2	COVER	St 35.8 / P265GH / C 22.8
3 *	GASKET	NON ASBESTOS
4 *	SEAT	AISI 304
5 *	VALVE	AISI 304
6 *	LEVER	AISI 304
7 *	FLOAT	AISI 304
8 *	AIR VENT	STAINLESS STEEL
9	BOLTS	STEEL 8.8

* AVAILABLE SPARE PARTS

