

FLOAT AND THERMOSTATIC STEAM TRAPS FLT 17

(Carbon Steel Body-Cast Iron Cover DN1/2"-1" ; DN 15-DN25)

DESCRIPTION

FLT 17 float and thermostatic (integral air vent) steam traps series are designed for all types of low and high pressure steam heating and process equipment.

Typical applications include unit heaters, heat exchangers, driers, jacketed vessels and all the applications where continuous drainage is essential. Connections are female screwed or flanged for horizontal or vertical installation.

MAIN FEATURES

Modulating discharge.
Discharges condensate at steam temperature.
Unaffected by sudden or wide load and pressure changes.
Excellent air discharge (by thermostatic air vent).

OPTIONS: Internal strainer (only on horizontal models).
SLR - steam lock release .
Equalizing plug and venting connection.

USE : Saturated and superheated steam.

AVAILABLE

MODELS : FLT 17-4.5 - FLT 17-10 - FLT 17-14 .

SIZES : 1/2", 3/4", 1" - DN15, DN20, DN25.

CONNECTIONS : Female screwed ISO 7/1 Rp (BS21)
Flanged DIN. Special flanges upon request.

INSTALLATION : Standard horizontal installation -
flow from right to left FLT17 (R-L)

Upon request:

-horizontal installation with the flow from left to right FLT17 (L-R)

-vertical installation with the flow from top to bottom FLT17 (V)

See IMI, installation and maintenance instructions.

PMA :Max.allowable pressure 16 bar

TMA: Max.allowable temperature 250 °C

PMO: Max.operating pressure 14 bar

TMO: Max.operating temperature 198 °C

How to order: i.e. FLT17-14 DN 15 DIN.

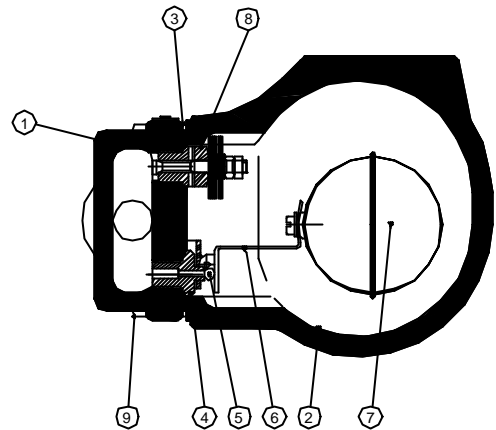

MATERIALS:

POS.NR.	DESIGNATION	MATERIAL
1	BODY	GS C-25
2	COVER	GGG 40
3 *	GASKET	NON ASBESTOS
4 *	SEAT	AISI 410
5 *	VALVE	AISI 410
6 *	LEVER	AISI 304
7 *	FLOAT	AISI 304
8 *	AIR VENT	STAINLESS STEEL
9	BOLTS	STEEL 8.8

* AVAILABLE SPARE PARTS

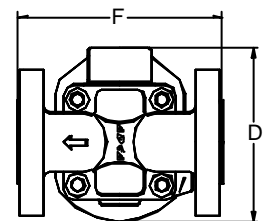
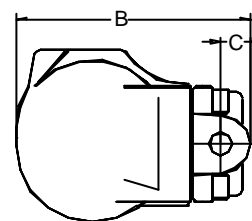

DIMENSIONS (mm)

SIZE	Screwed Ends				DIN Flanges			
	A	B	C	D	WEIGHT	F	WEIGHT	
DN							Kg	Kg
1/2"	95	178	23	128	5,2	150	6,7	
3/4"	95	178	23	128	5,2	150	7,2	
1"	95	178	23	128	5,2	160	7,7	

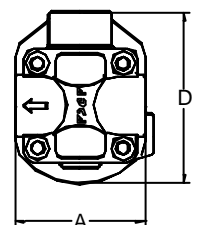

FLOW RATE CAPACITY IN Kg/h

MODEL	SIZE	DIFFERENTIAL PRESSURE (bar)												
		0,5	1	1,5	2	3	4,5	6	7	8	9	10	12	14
FLT17-4,5	1/2"- 1"	200	280	320	360	400	495							
FLT17- 10	1/2"- 1"	110	140	175	190	230	280	300	330	350	390	405		
FLT17-14	1/2"- 1"	70	100	120	140	155	190	210	220	225	230	260	280	300

Max.differential pressure
FLT 17-4.5 - 4.5 bar
FLT 17 -10 - 10 bar
FLT 17- 14 - 14 bar

Recommended safety factor : continuous 1.2 - 1.5 ; discontinuous flow 2 - 3 .