

Burners for gas two stages progressive (hi-low flame) or modulating (PID fully modulating) with the addition of the optional system modulation kit plus feeder. Fan at high pressurisation, combustion head with adjustment at high efficiency and high flame stability.

Disposition rationalized of the components with accessibility facilitated for the operations of setting and maintenance.

Gas train complete of working valve with flow adjustment, safety valve, gas pressure switch, filter stabiliser of gas pressure, completely assembled, electrically linked and tested.

Available versions with mechanical or electronic camme.

TECHNICAL DATA

MODEL		GB-Y 250 G/M CE	GB-Y 300 G/M CE
Thermal power min-max*	Mcal/h	300/900-1900	330/1000-2500
	kW	348/1044-2204	383/1000-2500
Flow-rate G20 (NATURAL GAS) min-max*	Nm ³ /h	35/105-222	39/117-292
Flow-rate G31 (LPG) min-max*	Nm ³ /h	14/41-86	15/45-113
Fuel		NATURAL GAS (second family) - LPG (third family)	
Combustible category		2R 2H 2L 2E+ 2Er 2ELL 2E(R) 38/P 3+ 3P 38 3R	
Intermittent operation (min. 1 stop every 24 hours) at 2 stages progressive and modulating			
Allowed environment conditions on running/stock		-15...+40°C/-20...+70°C, rel. humidity max 80%	
Maximum inlet pressure to the valves	°C	60	60
Min. pressure gas train D2*FS50 NATURAL GAS/LPG**	mbar	107/53	181/94
Min. pressure gas train DN65-FS65 NATURAL GAS/LPG**	mbar	46/31	84/54
Min. pressure gas train DN80-FS80 NATURAL GAS/LPG**	mbar	30/25	56/45
Min. pressure gas train DN100-F100-S100 NATURAL GAS/	mbar	21/22	39/38
Max pressure on the valve's inlet	mbar	200-500	200-500
Nominal electric power	kW	5.5	8
Fan motor	kW	5.5	7.5
Power absorbed	A	10.5	16.5
Auxiliary power absorbed	A	0.4	0.4
Power supply		3 - 400V, 1/N - 230V-50Hz	
Degree of electric protection		IP44	IP44
Noisiness***min-max	dB(A)	79-82	81-85
Weight****	kg	128	158

* Reference conditions: Room temperature 20°C - Atmospheric pressure 1013 mbars - Altitude 0m (sea level)

** Least pressure of feeding of the gas to the train to get the maximum power of the burner considering against pressure in chamber of value combustion 0 (zero)

*** Measured sonorous pressure in the laboratory combustion, with functional burner on beta boiler to 1 m of distance (UNI EN ISO 3746 law)

The illustrations and data here shown are indicative.

GENERAL BRUCIATORI S.r.l. reserves the right to bring, without any obligation of warning, any changes that would be appropriate to the continuing development of their products.

FIRING RATES: Thermal power - Pressure in combustion chamber

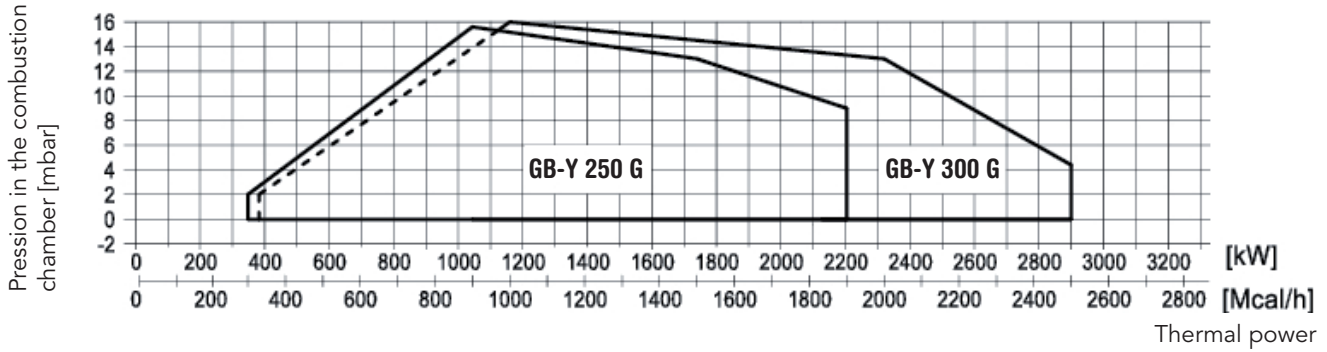

DIMENSIONS (mm)

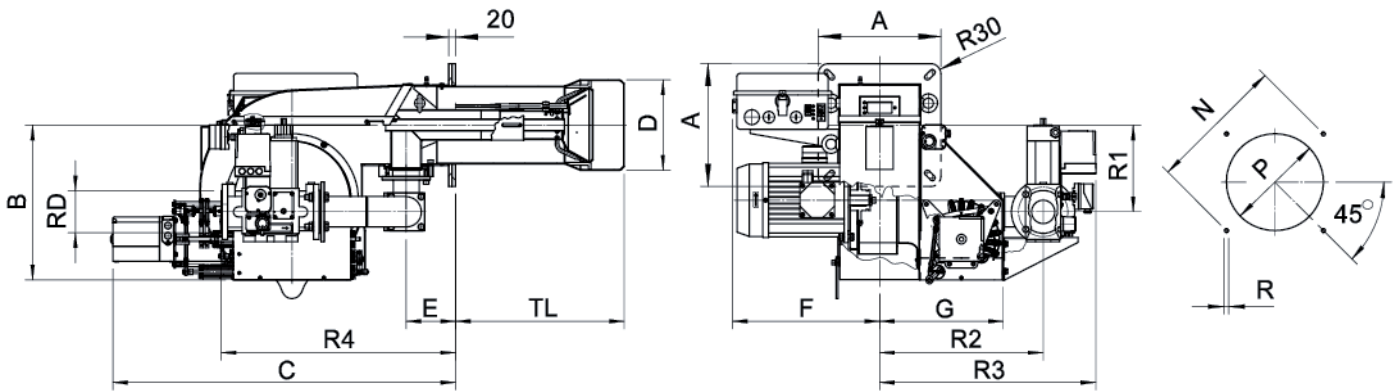

* Suggested dimension of connection between burner and generator

MODEL	A	B	C	D	E	F	G	TL	N _{min}	N*	N _{max}	P _{min}	P*	P _{max}	R	R1	R2	R3	R4	RD	Gas train weight
GB-Y 250 G/M CE - D2" - FS50	360	453	1010	265	145	432	363	495	396	424	438	280	280	320	M14	254	509	672	504	2"	22 kg
GB-Y 250 G/M CE - DN65 - FS65	360	453	1010	265	145	432	363	495	396	424	438	280	280	320	M14	254	480	634	688	DN65	37 kg
GB-Y 250 G/M CE - DN80 - FS80	360	453	1010	265	145	432	363	495	396	424	438	280	280	320	M14	254	480	647	708	DN80	47 kg
GB-Y 250 G/M CE - DN100 - FS100	360	453	1010	265	145	432	363	495	396	424	438	280	280	320	M14	254	480	654	748	DN100	57 kg
GB-Y 300 G/M CE - D2" - FS50	360	453	1010	270	145	432	363	495	396	424	438	280	280	320	M14	254	509	672	504	2"	22 kg
GB-Y 300 G/M CE - DN65 - FS65	360	453	1010	270	145	432	363	495	396	424	438	280	280	320	M14	254	480	634	688	DN65	37 kg
GB-Y 300 G/M CE - DN80 - FS80	360	453	1010	270	145	432	363	495	396	424	438	280	280	320	M14	254	480	647	708	DN80	47 kg
GB-Y 300 G/M CE - DN100 - FS100	360	453	1010	270	145	432	363	495	396	424	438	280	280	320	M14	254	480	654	748	DN100	57 kg