

DISCO® Swing Check Valves CB

DN 50 – 300 mm, PN 6 – 40

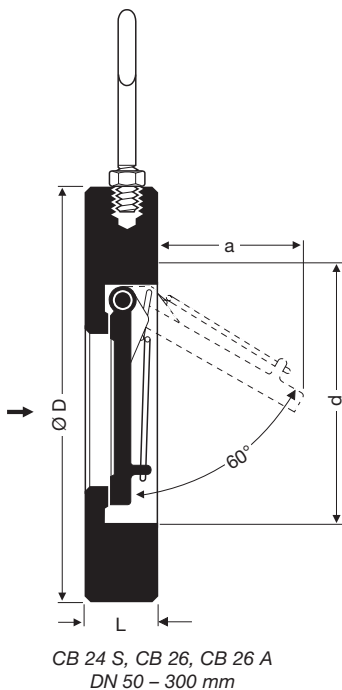
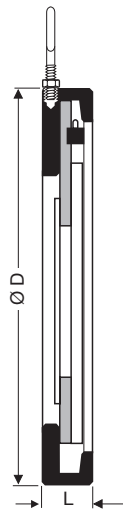
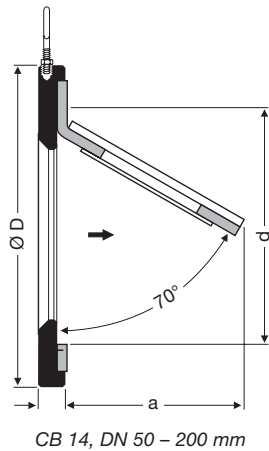

Application

Type	PN	
		For liquids, gases, vapours:
CB 14	16	CB 14 for water and compressed air
CB 24 S	16	CB 24 S for sea water, drinking water, swimming-pool water
CB 26	40	For low temperatures
CB 26 A	40	CB 26 A for aggressive fluids, drinking water, or swimming-pool water

Materials

Type	Part designation	Nominal sizes DN	EN reference	ASTM ¹⁾ equivalent
CB 14	Body	50 – 300 mm	1.0038 galvanized	A 284 B galvanized
	Flap	50 – 300 mm	NBR	NBR
CB 24 S	Body	50 – 100 mm	Bronze (CC 483K-GS)	B 505 C 90 700
		125 – 300 mm	Bronze (CC 332G)	B 148 Alloy 952
	Flap	50 – 300 mm	Bronze (CC 332G)	B 148 Alloy 952
CB 26	Body	50 – 200 mm	1.0460	A 105
		250 – 300 mm	1.0038	A 284 B
		50 – 80 mm	1.4581	A 351 CF 8 MC
	Flap	100 – 300 mm	GGG-40.3 (EN-JS 1025)	–
CB 26 A	Body	50 – 200 mm	1.4571	AISI 316 TI
		250 – 300 mm	1.4581	A 351 CF 8 MC
	Flap	50 – 300 mm	1.4581	A 351 CF 8 MC

¹⁾ Physical and chemical properties comply with EN grade.

Pressure/Temperature Ratings

Type	Nominal sizes DN	PN	PMA / TMA / [bar] / [°C]		
CB 14	50 – 300 mm	16	16 / -10	6 / 60	4 / 80
CB 24 S	50 – 300 mm	16	16 / -200	16 / 90	13 / 250 ²⁾
CB 26	50 – 200 mm	40	40 / -10	30 / 200	20 / 350
	250 – 300 mm	40	40 / -10	27 / 200	21 / 300
CB 26 A	50 – 300 mm	40	40 / -10	32 / 200	26 / 450

²⁾ Max. pressure/temperature rating for CB 24 S without springs.

CB Designs

Type	Sitzdichtung					Springs	
	metal-to-metal	NBR (-30 up to 110°C) ³⁾	EPDM (-40 up to 150°C) ³⁾	FPM (-25 up to 200°C) ³⁾	PTFE ⁴⁾ (-25 up to 200°C) ³⁾	without spring	special spring
CB 14	–	X ⁵⁾	–	–	–	X	–
CB 24S	O	X	O	O	–	O	–
CB 26	O	–	X	O	O	O	–
CB 26A	O	–	X	O	O	O	–

³⁾ Observe pressure / temp. ratings of the equipment ⁴⁾ Cover FPM ring with PTFE X : standard

⁵⁾ Flap made from NBR (Perbunan) Temp. range: -10°C up to 80°C O : optional

– : not available

Weights and Dimensions

Nominal size DN	Dimensions [mm]									Weight [kg]		
	[mm]	[in]	CB 14			CB 24 S, CB 26, CB 26 A			CB 14	CB 24 S	CB 26 CB 26 A	
		D	L	a	d ⁶⁾	D	L	a	d ⁶⁾			
50	2	98	14	45	47	98	17	40	50	0.7	0.9	0.9
65	2½	118	14	60	64	118	20	50	64	1.0	1.4	1.4
80	3	132	14	70	75	132	24	58	75	1.4	2.0	2.0
100	4	154	14	90	98	154	27	72	99	1.5	3.1	3.1
125	5	184	16	115	124	184	32	88	125	2.5	5.2	5.3
150	6	209	16	145	148	209	32	112	144	3.3	6.7	6.9
200	8	264	18	185	196	264	42	150	198	5.5	13.7	14.1
250	10	319	35	220	242	319	47	182	244	11.2	22.9	23.6
300	12	375	43	270	288	375	52	216	292	14.0	32.8	33.8

⁶⁾ Minimum flange bore and inside pipe diameter.

Pressure Drop Charts

The curves given in the chart are valid for water at 20 °C. To read the pressure drop for other fluids the equivalent water volume flowrate must be calculated and used in the graph.

The values indicated in the chart are applicable to valves with horizontal flow. With vertical flow insignificant deviations occur only within the range of partial openings.

$$\dot{V}_w = \dot{V} \cdot \sqrt{\frac{\rho}{1000}}$$

\dot{V}_w = Equivalent water volume flow in [l/s] or [m³/h]

ρ = Density of fluid (operating condition) in [kg/m³]

\dot{V} = Volume flow of fluid (operating condition) in [l/s] or [m³/h]

Opening Pressures

Differential pressures at zero volume flow.

Type	DN [mm]	Opening pressures [mbar]		
		Direction of flow		
		↑	→	↓
CB 14	50 – 150	8	0	1)
	200 – 300	15	0	

Type	DN [mm]	Opening pressures [mbar]			
		Direction of flow			
		without spring		with spring	
		↑	↑	→	↓
CB 24 S	50 – 150	5	12	7	1)
	200 – 300	8	15	7	
CB 26/	50 – 80	5	12	7	1)
CB 26 A	100 – 150	11	18	7	
	200 – 300	18	25	7	

1) Valves should not be used for downward flow applications, since the spring will not close the valve flap.

CB 14

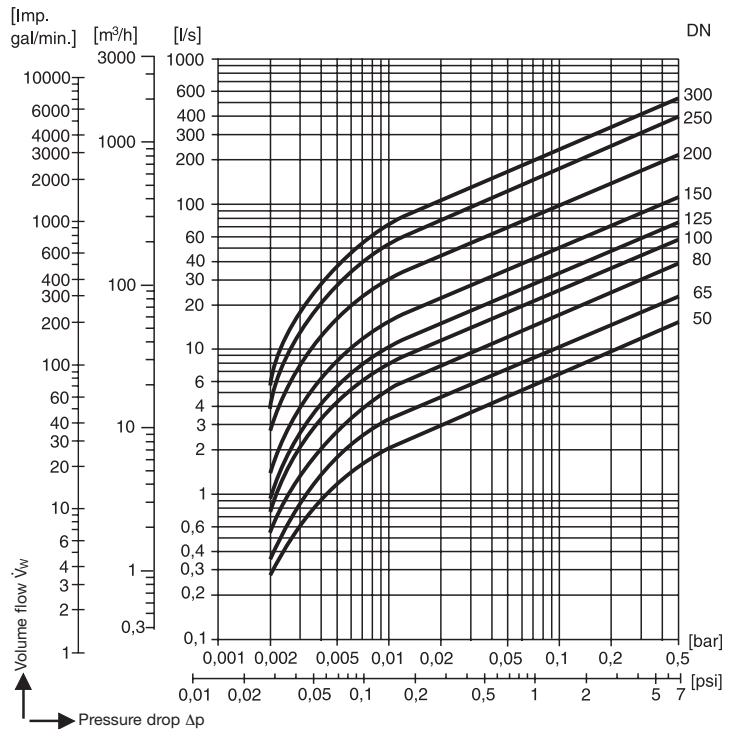

CB 24 S, CB 26, CB 26 A

